

## LUBE SERVICE SOLUTIONS It May Require a Factory Fix

### SEEPING NISSAN OIL COOLER

Imagine changing the oil and filter on a 2006 Nissan Maxima, and a few days later the customer encounters droplets of oil on the carport. The customer assumes the problem is a leaking oil filter and they return the vehicle to you for an inspection. Hurriedly, the lube tech replaces the oil filter and cleans the area containing the oily residue. A few days later the customer returns with the same leakage concern. Naturally, he is a little upset after having to return the second time with the same complaint. He is convinced the problem was due to technician error. The leakage didn't occur until your facility serviced the vehicle, so it must have been something that was done during the lube service.

Chances are the leakage had nothing to do with the oil filter. Most likely, the oil leakage is coming from a rubber gasket positioned behind the oil cooler (see Fig.1). The vehicles that are affected include: 2004 Quest, 2000–2006 Maxima, 2003–2006 Murano and 2002–2006 Altima vehicles equipped with a VQ30

or VQ35 engine. The inspection should begin with cleaning the oil cooler, oil filter and the surrounding area and allowing it to dry thoroughly. Run the engine and closely examine the oil filter, oil cooler and the area directly behind the oil cooler. If seepage is coming from the oil cooler gasket, a replacement gasket is available from Nissan (P/N B1304-43U00).

### WRANGLER OIL SEEPAGE

Owners of 2007–2008 Jeep Wranglers equipped with a 3.8L engine may encounter oil seepage. The condition is often misdiagnosed as a leaking oil filter, oil pan gasket, front or rear crankshaft seal, or a leaking timing gear housing gasket.

Clean the residue from the engine. Once the area is thoroughly dry, run the engine and closely examine the area around the timing gear housing. Fluorescent dye added to the oil and a black light can be beneficial in locating the source of the leak. The leak may be due to the porosity of the timing gear housing. The porous area is located on the surface that mates to the engine block. The vehicle manufacturer offers a revised timing gear housing and the necessary gaskets under P/N 68003438AA.

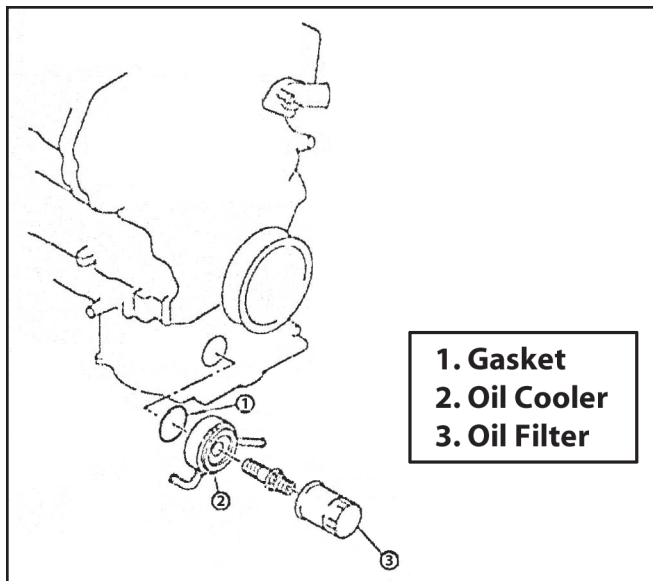

FIG. 1

Courtesy of Nissan

### ILLUMINATED OIL PRESSURE LAMP

Complaints of an intermittent or constantly illuminated oil pressure lamp from owners of 2007 Chrysler 300, Charger and Magnum vehicles may be due to a damaged oil pressure switch harness.

If the customer complains of an illuminated oil pressure lamp, examine the oil pressure switch harness in the area of the A/C compressor pulley. If the pulley has made contact with the harness, the harness should be rerouted and secured with a tie strap (see Fig. 2). For liability reasons, always verify that the engine has sufficient oil pressure.

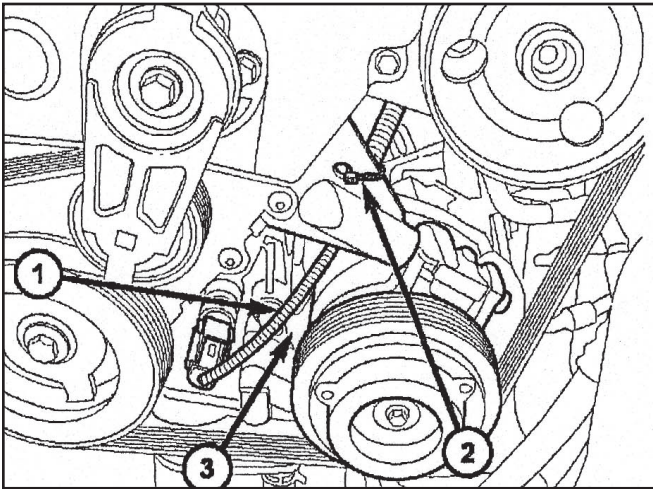

**FIG. 2**

*Courtesy of Chrysler*

## **OIL PRESSURE SENSOR HARNESS**

- 1. Oil Pressure Switch Harness**
- 2. Tie Strap**
- 3. 20 mm (3/4 inch) Clearance to the A/C Compressor Pulley**

## **CORRECT OIL FILTER INSTALLATION**

Fast in and out spells profit in the fast lube service business. The number of vehicles that pass through some lube centers on a daily basis is almost unbelievable. It is imperative that the technicians remain focused and that they are not distracted by others, and especially by a phone call. Distractions result in filters and drain plugs not being adequately tightened, or failure to install the oil. Further, the lube tech should never rely on his experience or memory when selecting an oil filter for an application. When a lube tech gets overconfident and installs the incorrect oil filter, major engine damage is almost certain. We have seen filters fall off the engine due to a filter with an incorrect thread size being installed.

There is no warranty provision to cover a damaged engine due to incorrect parts being installed. Always reference parts information guides when selecting the oil filter for an application. If the application data is not complete, do not rely on the physical characteristics and dimensions of the filter to make an installation.

## **SERVICING AIR FILTERS**

The normal air filter inspection usually involves an examination of the filter element to determine the

amount of debris embedded in the filter media, which can restrict the air flow. Trust me, there is more to inspect. Engines are thirsty for air. It requires approximately ten thousand gallons of air to burn one gallon of fuel. While most technicians understand and look at the condition of the air filter, few take the time to inspect the housing that contains the filter. The system must be properly sealed to prevent debris from entering the engine. A damaged housing can result in mechanical damage to the engine and also contaminate the mass air flow sensor, resulting in major performance and drivability issues. If you fail to catch a damaged housing or latch, the customer may try to hold you responsible for any engine damages incurred.

Damage to the filter housing can occur due to improper filter installation procedures, plastic latches breaking from fatigue, and heat-related damage resulting in warpage of the housing. Police cars and taxis are good examples of housings that warp due to long periods of idling, promoting high underhood temperatures. Ford has a redesigned air box (P/N 8W7Z-9600-A) for the 2005–2008 Crown Victoria Police Interceptor vehicles, due to case distortion from intense heat. The symptoms may include an illuminated MIL lamp, accompanied by a loss of power or a buck/jerk condition on acceleration, especially in cold temperatures. The performance condition is due to unmetered air entering the engine, affecting the mass air flow sensor readings. On vehicles equipped with a mass air flow sensor, any air entering the engine must pass through the sensor to be measured, to insure the proper fuel mixture.

Pay special attention to the diesel applications, as damaged air boxes are not uncommon. The diesel engine inhales a large volume of air and anything else in the immediate area. Foreign materials can quickly destroy turbochargers and engine components. When the air filter becomes too restricted, the engine can pull the filter from its mounted position or distort the air box, allowing unfiltered air to enter the engine, resulting in major engine or turbocharger damage.

Take the time to do the job in a professional manner. Make certain the components are properly installed. Run the engine and check for signs of leakage. Treat the service as if your job depended upon it.

LARRY HAMMER  
 Technical Services  
 Mighty Distributing System of America



**MIGHTY: THE PMPROS**

[www.mightyautoparts.com](http://www.mightyautoparts.com)